

ZMI High Performance HSPMI

P/N	DESCRIPTION	OPTICAL
8080-0360-01	HSPMI only	Linear displacement resolution (nominal) 0.31 nm (ZMI 2000) 0.15 nm (ZMI 4000)
8080-0360-02	HSPMI with horizontal mount	Clear aperture through interferometer 7.6 mm with respect to datums 7.3 mm centered on input aperture
8080-0360-03	HSPMI with vertical mount	Input-to-primary beam location 0 μm \pm 100 μm
8080-0360-11	HSPMI with left FOP	Input-to-primary beam parallelism \leq 1000 μrad
8080-0360-12	HSPMI with left FOP and horizontal mount	Primary-to-secondary beam spacing 12.7 mm
8080-0360-13	HSPMI with left FOP and vertical mount	Primary-to-secondary beam parallelism \leq 15 μrad
8080-0360-21	HSPMI with right FOP	Signal Efficiency 60% with plane mirror having 99% reflectance at 633 nm at normal incidence
8080-0360-22	HSPMI with right FOP and horizontal mount	
8080-0360-23	HSPMI with right FOP and vertical mount	

PHYSICAL CHARACTERISTICS	
Dimensions	See Figure
Weight	< 300 grams
Materials	Available on request

COMPONENTS	
Included	High Performance HSPMI (see P/N section)
Not Included	Target Plane Mirror (see P/N section)

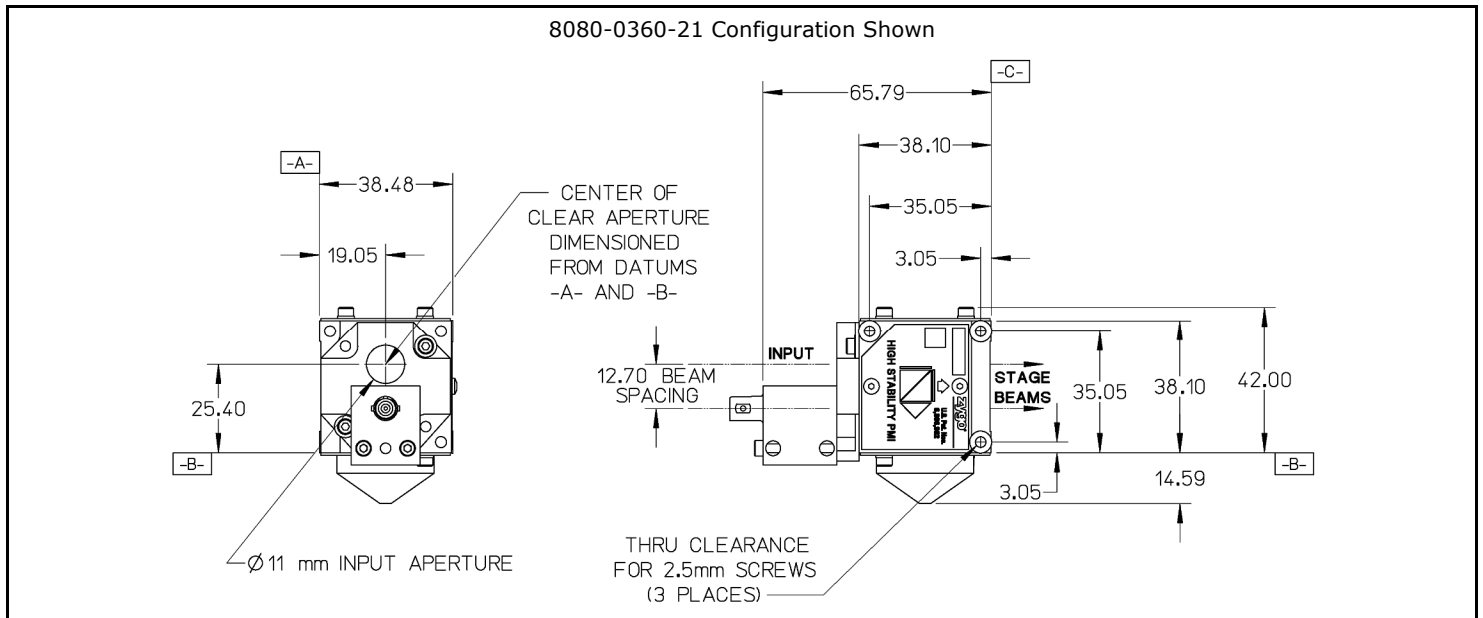

ZMI High Performance HSPMI

SAMPLE HSPMI CONFIGURATIONS

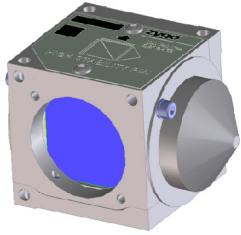

Straight beam,
no FOP
no mount
8080-0360-01

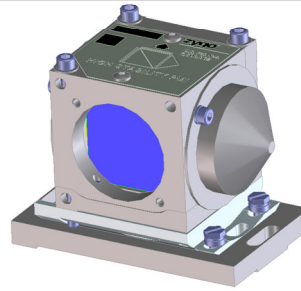

Straight beam,
no FOP
horizontal mount
8080-0360-02

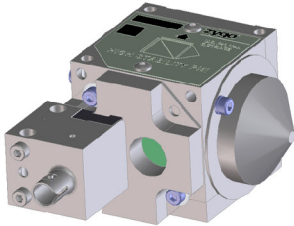

Straight beam,
FOP left
no mount
8080-0360-11

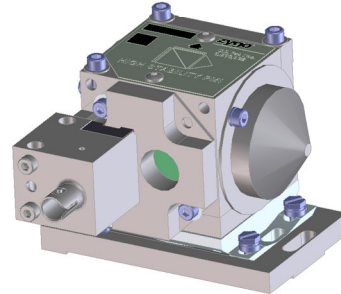

Straight beam,
FOP left
horizontal mount
8080-0360-12

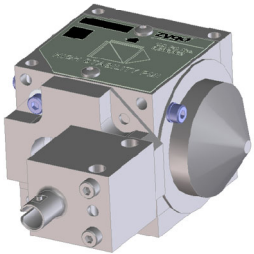

Straight beam,
FOP right
no mount
8080-0360-21

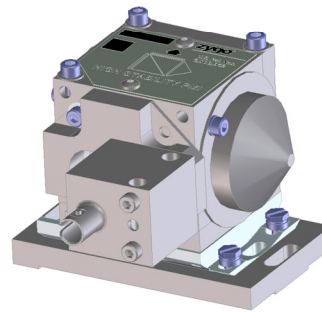

Straight beam,
FOP right
horizontal mount
8080-0360-22